

SkelStart

ENGINE START MODULE

12V & 24V

INSTALLATION GUIDE & USER MANUAL

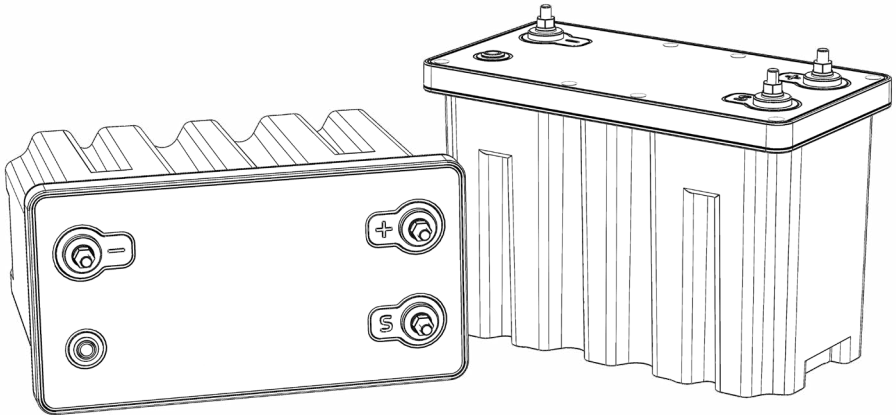

Keep this user manual in your vehicle.

skeleton⁺

www.skelstart.com

Installation manual & troubleshooting guide

Table of contents

1. SkelStart Engine Start Module	4
2. Handling your SkelStart	4
2.1 Personal safety & PPE	4
2.2 Safety warnings	4
3. SkelStart specifications	6
4. Unpacking and installation	8
4.1 Aftermarket accessories required for retrofit installation	8
4.2 Unpacking the SkelStart	8
4.3 SkelStart mounting location	9
4.4 Electrical connection identification	9
4.5 Cable selection	9
4.6 Wiring instructions	10
4.7 Skelstart 12V installation schematics	12
4.8 SkelStart 24V installation schematics	13
5. Charge status	14
5.1 Button controls and LED statuses	14
5.2 Switching a SkelStart on/off	14
6. Handling	15
6.1 Handling a charged SkelStart & discharging a SkelStart	15
7. Maintenance & disposal	16
7.1 Taking care of your SkelStart	16
7.2 Disposal	16
8. Troubleshooting	17
8.1 Jumpstarting	17
8.2 The first things to check if the Skelstart is not working as intended	17
8.3 Troubleshooting guides	17
8.3.1 SkelStart is not working after installation	18
8.3.2 Jumpstarting	20
8.3.3 SkelStart stops working	22

1. SkelStart Engine Start Module

The SkelStart Engine Start Module enables drivers to start a vehicle engine in situations where the engine cannot be started by normal batteries due to (for example) aged batteries, extreme weather conditions, or where there is insufficient power in the batteries to start the engine.

The SkelStart is based on supercapacitors, which are high power energy storage devices, ideal for high-current applications such as cranking large diesel engines.

The SkelStart is able to supply sufficient starting current to start the engine even at -40°C , eliminating risk of downtime event that could otherwise happen with regular batteries.

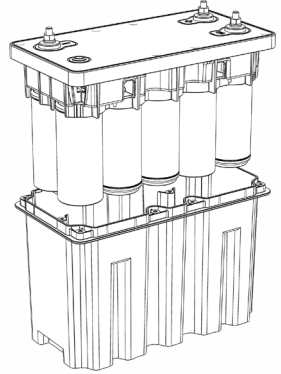

2. Handling your SkelStart

2.1 Personal safety & PPE

While handling SkelStart:

- If possible, always discharge the module before handling.
- Wear safety shoes.
- Wear cut resistant working gloves.
- Use tools with low voltage isolation to avoid short circuiting of power terminals.

In the event of cell venting:

- Use nitrile gloves.
- Use protection glasses.
- Do not breathe in the fumes produced by a supercapacitor cell venting.

2.2 Safety warnings

SkelStart is **NOT A BATTERY** and must be handled differently. Please review these safety warnings.

NO WARRANTY WILL BE HONORED IF ANY MODIFICATIONS OR REPAIRS HAVE BEEN ATTEMPTED BY THE CUSTOMER.

WARNING



READ AND FULLY UNDERSTAND THIS MANUAL BEFORE INSTALLING AND USING THE DEVICE.

Failure to follow installation and operating instructions may result in permanent damage of the device and in extreme cases can lead to injury and fire.



THIS IS NOT A BATTERY. DO NOT JUMP START. HIGH CURRENT HAZARD.

Do not connect battery or jump start cables across the STARTER PLUS and BATTERY NEGATIVE terminals. Such connection will cause a similar effect as shorting jumpstart cables, as the supercapacitor pack inside SkelStart can take in extreme amounts of current (up to several kA).

Charging must be done ONLY through Battery Positive and Battery Negative terminals, where internal charging circuit will charge the SkelStart supercapacitor pack as intended, while maintaining proper cell balancing functionality.

Refer to Troubleshooting guide: Jumpstarting for correct jumpstarting procedure.



DO NOT SHORT CIRCUIT WHEN CHARGED. HIGH CURRENT HAZARD.

Shorting Starter Plus and Battery Negative terminals on charged SkelStart will lead to extreme current flow between terminals (up to 17.8 kA) causing sparks, molten metal drops and/or possible supercapacitor pack damage.



DO NOT HANDLE WHEN CHARGED. HIGH CURRENT HAZARD.

SkelStart must be fully discharged and have electrical shorting wire attached before handling. Refer to Handling charged SkelStart & SkelStart discharging for correct procedure.



DO NOT CONNECT IN ANY OTHER WAY THAN INSTRUCTED.

Connecting SkelStart in a different way than specified in the manual will result in permanent damage of the device and in extreme cases might lead to fire. Ensure that all installation steps are followed correctly.



DO NOT EXCEED MAXIMUM OPERATING VOLTAGE.

Overvoltage will lead to permanent damage of SkelStart internal electronics, making device unusable.



DO NOT OVERHEAT.

Operation above +65 °C / +149 °F causes rapid electrochemical degradation, resulting in increase of ESR (equivalent series resistance, or internal resistance) and decrease in capacitance. For longest possible device lifetime operational temperature should be below +50 °C / +122 °F.



DO NOT CONNECT ACCESSORY LOADS.

SkelStart has much less stored energy compared to a battery, meaning any accessory loads will quickly discharge the device. SkelStart must be used only for engine cranking.



DO NOT DROP. DO NOT USE AS A STRUCTURAL COMPONENT.

3. SkelStart specifications

12V 2000 CCA	Unit	Value
Cold Cranking Amps (CCA)*	A	2000
Maximum Peak Current (1 sec current) **	A	3543
Peak power *	kW	38.5
Charged full voltage	V	13.1
Energy	Wh	32.4
Rated Capacitance	F	1360
Individual Cell Capacitance	F	3400
Charging current	A	20 (max)
Continuous input voltage range	V	9-16
Continuous input voltage range with specified charge time	V	11.5-16
Recharge time (from 0 V)	min	20
Dimensions	mm in	328(l) x 171(w) x 241(h) 12.91 x 6.73 x 9.49
Operating temperature	°C °F	-40 to +65 -40 to +149
Standby current draw	mA	<10
Weight	kg lbs	8.5 18.7

* Based on 1s ESR

** The stated maximum peak current should not be exceeded during use. If the limit is to be exceeded by the customer, Skeleton must be consulted beforehand and give approval for the exceeded power load.

24V 1145 CCA	Unit	Value
Cold Cranking Amps (CCA)*	A	1145
Maximum Peak Current (1 sec current) **	A	2360
Peak power *	kW	65.7
Charged full voltage	V	26.2
Energy	Wh	32.4
Rated Capacitance	F	340
Individual Cell Capacitance	F	3400
Charging current	A	20 (max)
Continuous input voltage range	V	18-32
Continuous input voltage range with specified charge time	V	23-32
Recharge time (from 0 V)	min	10
Dimensions	mm in	328(l) x 171(w) x 241(h) 12.91 x 6.73 x 9.49
Operating temperature	°C °F	-40 to +65 -40 to +149
Standby current draw	mA	<10
Weight	kg lbs	8.5 18.7

* Based on 1s ESR

** The stated maximum peak current should not be exceeded during use. If the limit is to be exceeded by the customer, Skeleton must be consulted beforehand and give approval for the exceeded power load.

4. Unpacking & installation

4.1 Aftermarket accessories required for retrofit installation

The additional materials that may be needed for installation are listed below. These items are not included with the SkelStart, but may be necessary for isolating other vehicle electronic non-starting loads from the starter system.

- Pre-Insulated Submersible Connector with 3 ports (Part Number: ISPB2/0-3) or 4 ports (Part Number: ISPB2/0-4).
- Instead of a pre-insulated submersible connector, a simple M10 or 3/8" bolt, washer, and nut connection can be used to connect non-starter vehicle loads to the batteries.
- For installation with M10 or 3/8" bolt, washer, and nut, electrical insulation material - heat shrink - is required for proper isolation.
- Appropriately sized cables with crimp terminals (refer to section **4.5 Cable selection** and **4.6 Wiring instructions**), corrugated wire loom and tie wraps.



Tools required (not supplied):

- Large compound-action crimp tool (or similar)
- Standard shop tools

4.2 Unpacking the SkelStart

Remove the SkelStart from the shipping box by lifting it up while holding from plastic enclosure top side up. It weighs 18.7 pounds (8.5 kg) and is significantly lighter than a similarly sized lead acid or AGM battery.

DO NOT lift the SkelStart from electrical shorting wire attached to Starter Plus and Battery Negative terminals. Remove and discard electrical shorting wire entirely before installation.

Retain the shipping materials until the unit has been inspected and is determined to be operational.

4.3 SkelStart mounting location

SkelStart external dimensions are according to Group 31 batteries.

SkelStart installation might require installation of a bracket or a shelf on which to place the module. The shelf must be in a safe location, away from any direct heat sources.

If SkelStart is installed in a Class 8 truck, it can be installed in addition to batteries or replace one of the batteries in the battery box (depending on free space available).

Do not use SkelStart as only energy source on the vehicle. SkelStart is designed to provide power only for engine cranking. Batteries are still needed to supply other vehicle auxiliary/hotel loads.

4.4 Electrical connection identification

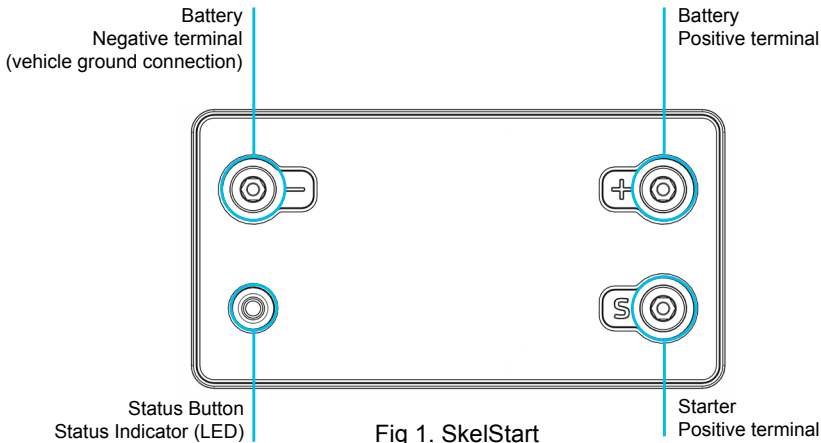

4.5 Cable selection

To install the SkelStart, you need new cable from SkelStart Starter Positive terminal to starter solenoid positive (+) terminal; from SkelStart Battery Negative to the vehicle ground or vehicle battery negative terminal, and from SkelStart Battery Positive terminal to vehicle battery positive (+) terminal (12V or 24V).

Length of cable (m)	4.5–6	6.1–9	9.1–12
Length of cable (ft)	15-20	20.1-30	30.1-40
Cable size (mm ²)	35	50	70
AWG	2	0	2/0

4.6 Wiring instructions

1. Before installation, remove all the cables from the vehicle batteries. The vehicle batteries must be charged. Clean the battery terminals to remove any oxidation or grease.

NOTE: Do not connect the SkelStart before instructed to do so!

2. Most vehicle manufacturers connect the alternator and other vehicle power cables to the starter solenoid's positive terminal. Therefore, **all the cables connected to starter solenoid's positive (+) terminal must be removed** (Fig. 2 cables 1, 2, 3 - cable 3 can consist of several separate cables or unified into one cable). Note: the starter can include an integrated magnetic switch, in which case the short cable from the magnetic switch to the starter can remain connected to the positive starter terminal.

WARNING



Ensure that alternator and other vehicle loads are removed from starter's positive terminal.

3. The cables removed from the positive starter solenoid terminal must be connected together using a terminal block or a nut-bolt connection (use spring washer or locknut for increased vibration resistance of the connection). This connection must then be isolated from the rest of the vehicle and mounted securely to prevent free movement of the connection. This can be achieved by bundling the cables together using cable ties and covering the connection with heat shrink (Fig 3. cables 1,2,3). Note: the connection must be fully isolated from the mass of the truck and should be secured in such a way that vibration, abrasion or corrosion cannot cause a short circuit.

4. Construct a new cable to connect the SkelStart Starter Plus to the positive terminal of the Starter Solenoid (Fig. 3 cable 4). Recommended cable size can be found in **4.5 Cable Selection** section and is based on the length of the cable.

5. Construct a new cable to connect the SkelStart Battery Positive vehicle battery positive (+) line (Fig. 3 cable 6). The cable size should be at least 25 mm² / 3 AWG for lengths of <5 m or <16.4 ft and 35 mm² / 2 AWG when the cable length exceeds 5 m or 16.4 ft.

6. Finally, construct a new cable to connect SkelStart Battery Negative terminal with vehicle ground on vehicle battery negative (-) terminal (Fig. 3 cable 5). This cable must be sized according to **4.5 Cable selection** section. Do not connect the cable yet.

7. After assembling the cables, mount the SkelStart securely in place and connect SkelStart Battery Positive terminal with vehicle battery positive (+) terminal. Then connect SkelStart Battery Negative terminal with vehicle ground or with vehicle battery negative (-) terminal. Reconnect vehicle batteries. Attach new starter cable to vehicle starter solenoid positive terminal (+), but do not connect the starter cable to SkelStart. Do not exceed tightening torque values specified on SkelStart terminals when connecting cables to SkelStart.

WARNING



Ensure that only newly constructed starter cable and magnetic switch cable (if applicable) are connected to starter. No other connections to starter are permitted!

8. Before making the final connection to SkelStart Starter Plus terminal, measure the voltage between the starter cable and both the positive and negative connections on the SkelStart. In both cases, the multimeter should read 0 V. Voltage reading other than 0 V between the starter cable and either the positive or negative connections on the SkelStart indicates that the starter solenoid may be unreliable or that there is another path from the solenoid to the batteries. **Connecting the SkelStart in this state can be dangerous and must be corrected before continuing with the installation.**

9. If the voltage reading between the starter cable and both of SkelStart positive and negative connections reads 0V, then the cable leading from the starter can be connected to the SkelStart. Do not exceed maximum tightening torque specified on SkelStart.

10. Before switching on the SkelStart, ensure that all the connections have been fastened securely. To switch on the SkelStart, press and hold Status Button for 5 seconds.

11. Charging has been successfully initiated when green Status Indicator (LED) starts to flash slowly. Status Indicator will continue to flash until the SkelStart is fully charged, which might take up to 20 minutes.

12. When the charging stops, the SkelStart is ready to be used to start your engine!

4.7 SkelStart 12V installation schematics

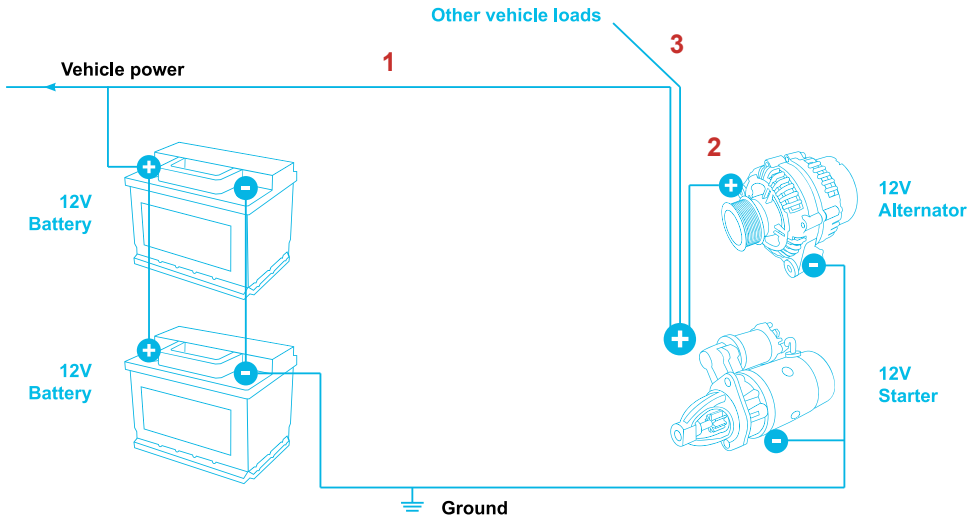

Fig 2a. 12V system **before** SkelStart installation

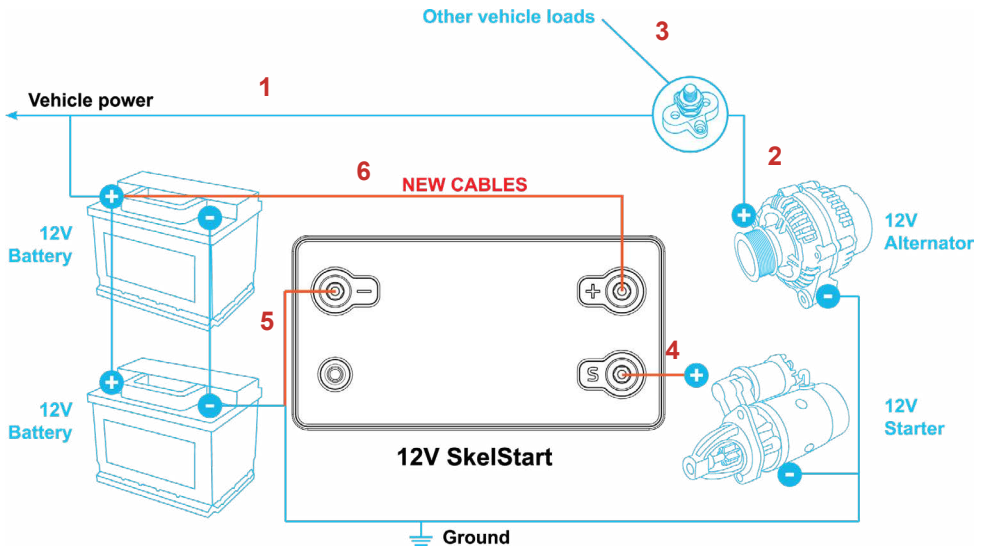

Fig 3a. 12V system **after** SkelStart installation

*12V SkelStart can be used to replace an existing battery.

In 12V, a parallel connection with at least one battery is required.

4.8 SkelStart 24V installation schematics

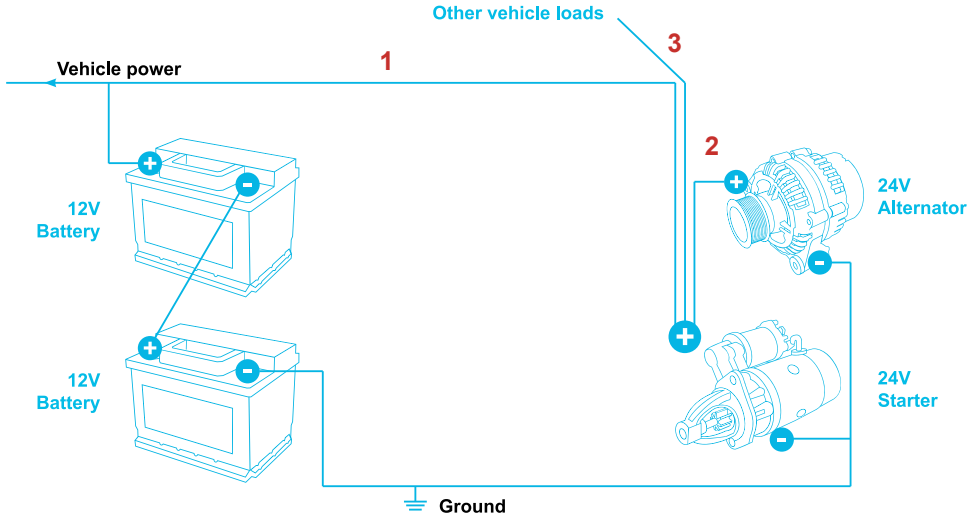

Fig 2b. 24V system **before** SkelStart installation

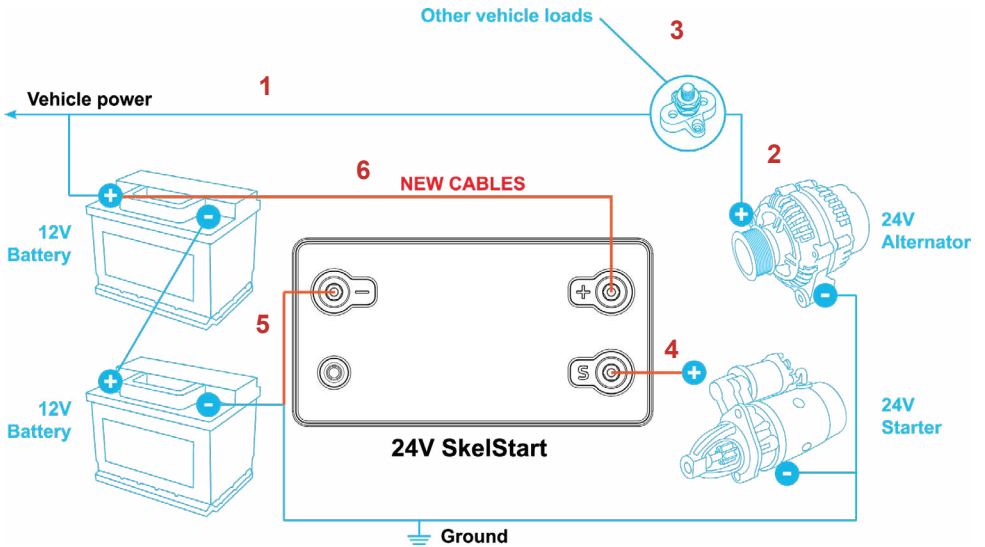

Fig 3b. 24V system **after** SkelStart installation

*24V SkelStart can be used to replace existing battery.

In 24V, minimum of two batteries connected in series required.

5. Charge status

5.1 Button controls and LED statuses

Description	Action	Diagnostic tools
Turning SkelStart ON.	Hold the button down for 5 seconds.	LED is lit for 5 seconds after SkelStart is turned ON.
Turning SkelStart OFF.	Hold the button down for 5 seconds.	LED is lit for 1 second after SkelStart is turned OFF.
SkelStart is charging.		LED will blink continuously while the SkelStart is charging.
Get status update.	Press the button once.	If LED is lit for 5 seconds, SkelStart is ready for use. If LED blinks twice, the SkelStart has charge but is not fully charged.

5.2 Switching a SkelStart on/off

The SkelStart includes a green Status Indicator (LED) that displays the status of the unit when the button is pressed. Holding the button for 5 seconds will turn the device ON or OFF.

NOTE: This will only affect the charging circuit; it will not discharge the device or make it safe to handle if fully charged.

A short press of Status Button will indicate the state of the device; staying lit for 5 seconds will indicate that the device is ON. A blinking LED shows that the SkelStart is charging. In the OFF state, there is no response.

6. Handling

6.1 Handling a charged SkelStart & discharging a SkelStart

For storage, SkelStart must be discharged to 0V and must have an electrical shorting wire attached between Starter Plus and Battery Negative terminals.

Storing discharged SkelStart without attaching electrical shorting wire may result in residual charge between Battery Negative and Starter Plus terminals, which can cause sparks and heat if these terminals are later electrically shorted.

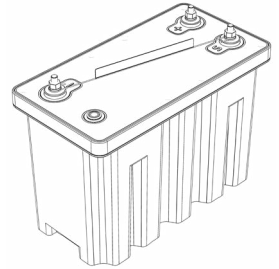

Before working on any SkelStart that has no electrical shorting wire attached, measure voltage between SkelStart Starter Plus and the Battery Negative terminals.

- If the voltage on terminals is above 2V, SkelStart must be discharged with external load (power resistor or electronic load is recommended). External load must be sized correctly and provided with sufficient cooling to handle power dissipation during discharge.
- If the voltage on terminals is below 2V, the module is considered safe for handling.

7. Maintenance & disposal

7.1 Taking care of your SkelStart

Terminal connections must be periodically checked for oxidation or for loose connections and should be cleaned or tightened as necessary. Prior to removal or system maintenance, ensure that the module has been discharged. No other maintenance is necessary.

7.2 Disposal

Do not incinerate, crush, or dispose your SkelStart in trash. Do not recycle SkelStart with batteries. Dispose SkelStart in accordance with the local regulations for electronic waste.

8. Troubleshooting

8.1 Jumpstarting

If a jump start is required, refer to Troubleshooting guides: Jumpstarting for correct jumpstarting procedure.

WARNING



DO NOT CONNECT BATTERY OR JUMP START CABLES ACROSS THE STARTER PLUS AND BATTERY NEGATIVE TERMINALS.

8.2 The first things to check if the SkelStart is not working as intended

Do an external visual check and look for damages. If no external damages are visible, start electrical test:

- Make sure that vehicle battery is connected to SkelStart Battery Plus and Battery Negative terminals.
- Hold the button down for 5 seconds and check if the module turns ON or OFF. SkelStart must be turned ON, meaning that after holding the button down for 5 seconds, the LED must be active for 5 seconds.
- If SkelStart is turned ON and vehicle battery is connected, SkelStart must start charging internal supercapacitor pack, which is indicated by blinking Status Indicator.
- Measure voltage between SkelStart Starter Plus and Battery Negative terminals. Voltage should be rising and Status Indicator should be blinking until the SkelStart is fully charged.
- If voltage between SkelStart Starter Plus and Battery Negative terminals does not rise to specified SkelStart output voltage within 20 minutes (12V SkelStart) or 10 minutes (24V SkelStart), view the Troubleshooting Guides on pages 16-21.

8.3 Troubleshooting guides

Please find troubleshooting guides after this page:

- 8.3.1 SkelStart is not working after installation
- 8.3.2 Jumpstarting
- 8.3.3 SkelStart stops working

8.3.1 SkelStart is not working after installation

Troubleshooting guide

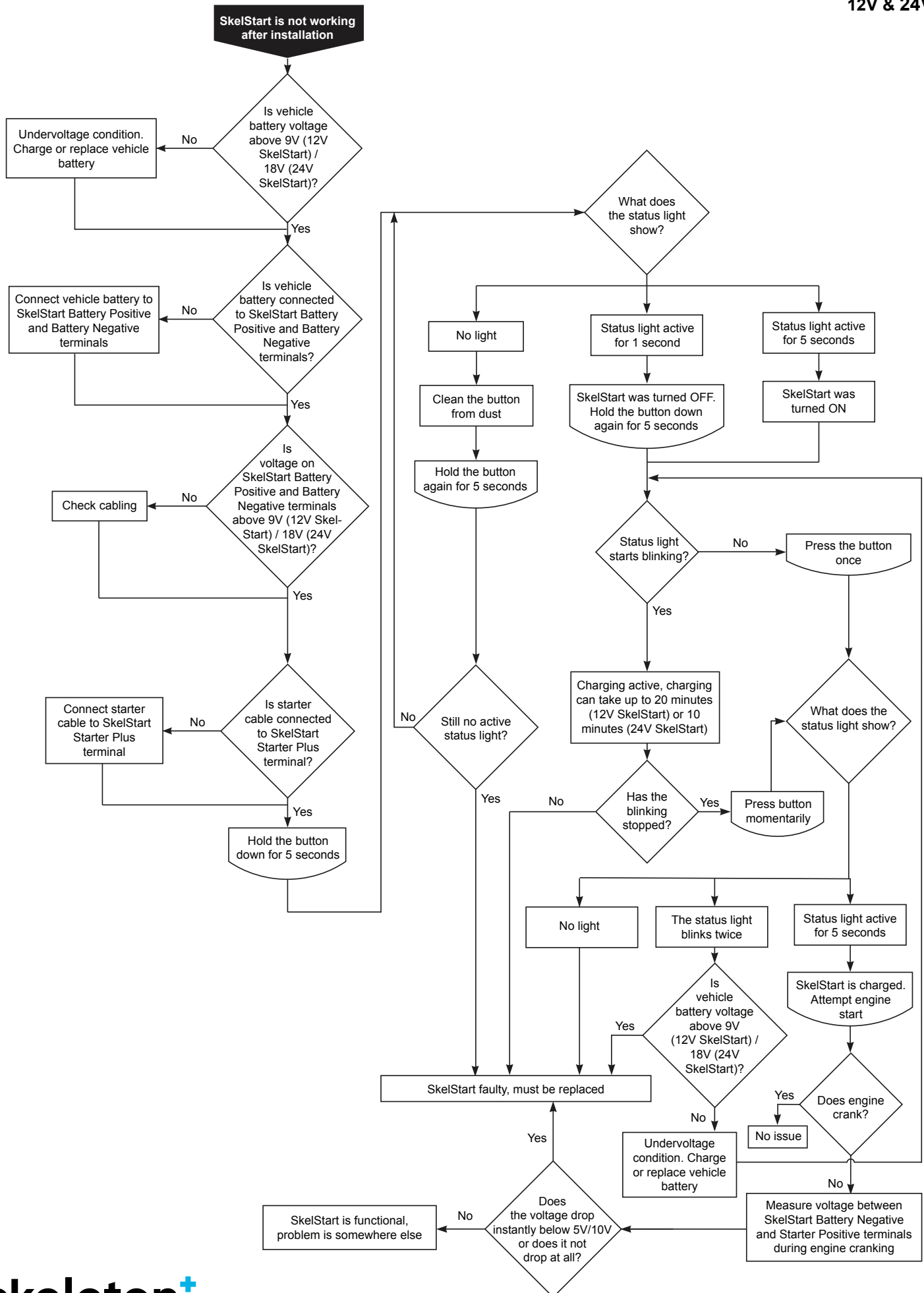

8.3.2 Jumpstarting

Troubleshooting guide

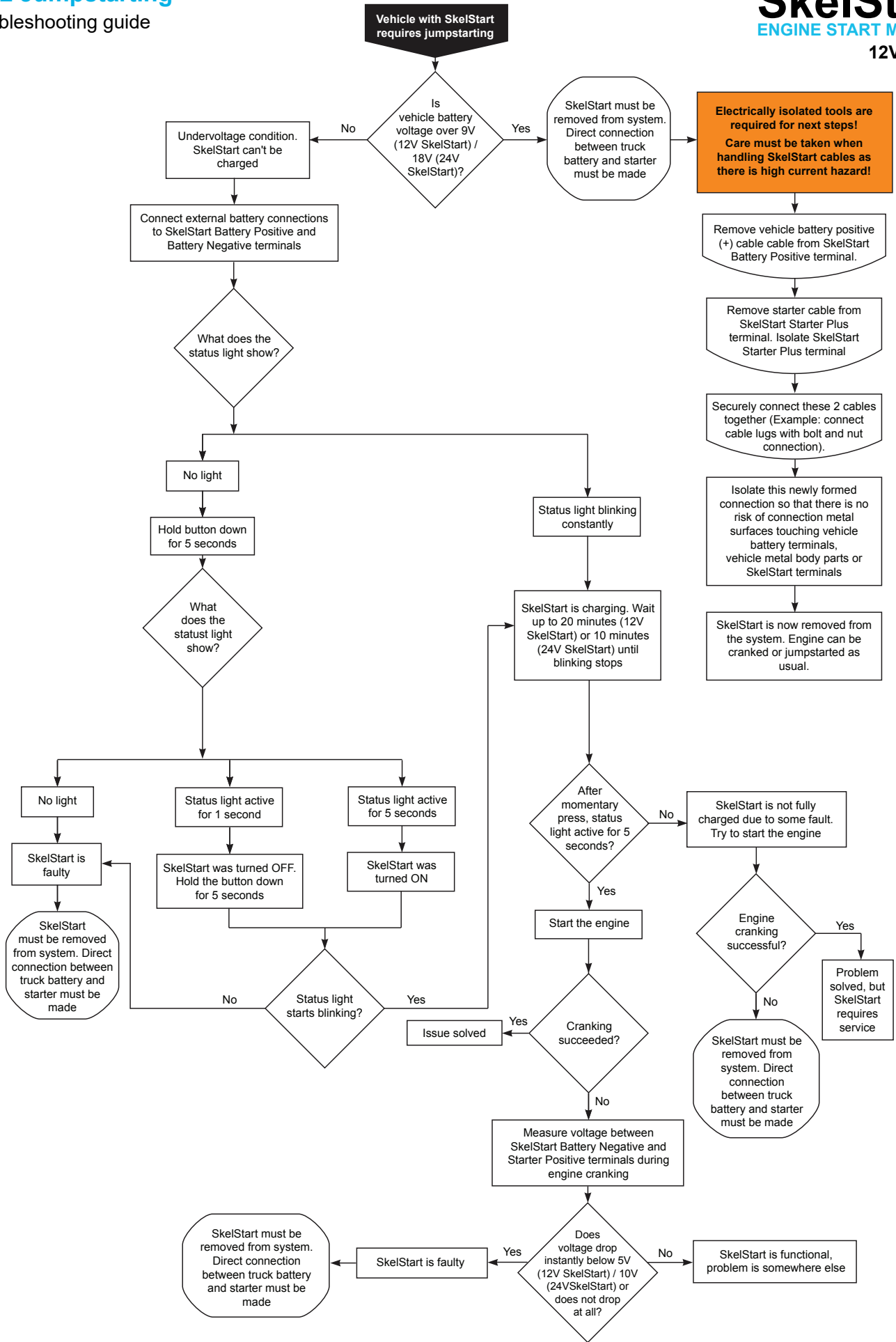

8.3.3 SkelStart stops working

Troubleshooting guide

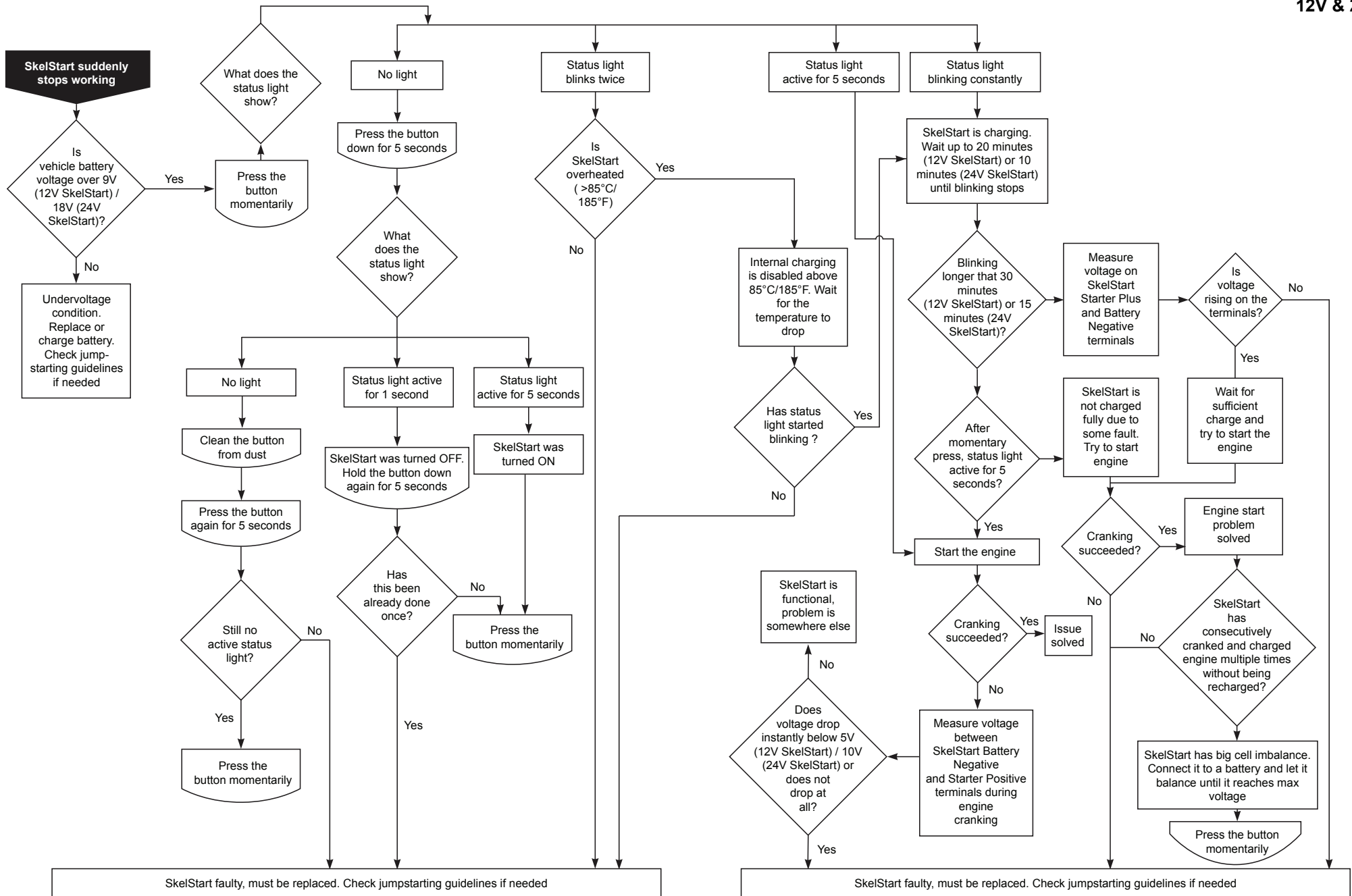

skeleton⁺

www.skeletontech.com

Copyright © 2023 Skeleton Technologies GmbH. All rights reserved.
230627-02-PR-SkelStart-Manual-LV-ENG-A5-1E Rev. 4600071-A